

**PERTH COLLEGE**  
**YEAR 12 PHYSICS**  
**SEMESTER TWO EXAMINATION 2010**



**Question/Answer Booklet**

Name \_\_\_\_\_

**Time allowed for this paper**

Reading time before commencing work: ten minutes

Working time for paper: three hours

**Materials required/recommended for this paper**

***To be provided by the supervisor***

This Question/Answer Booklet

Formulae and Constants Sheet

***To be provided by the candidate***

Standard items: pens, pencils, eraser, correction fluid/tape, ruler, highlighters

Special items: non-programmable calculators satisfying the conditions set by the Curriculum Council for this course, drawing templates, drawing compass and a protractor

***Important note to candidates***

No other items may be taken into the examination room. It is **your** responsibility to ensure that you do not have any unauthorised notes or other items of a non-personal nature in the examination room. If you have any unauthorised material with you, hand it to the supervisor **before** reading any further.

## Structure of this paper

Section	Number of questions available	Number of questions to be attempted	Suggested working time (minutes)	Percentage of exam
Section One: Short answer	14	14	54	30
Section Two: Extended answer	7	7	90	50
Section Three: Comprehension and data analysis	2	2	36	20
<b>Total</b>				<b>100</b>

## Instructions to candidates

1. The rules for the conduct of Western Australian external examinations are detailed in the *Year 12 Information Handbook 2010*. Sitting this examination implies that you agree to abide by these rules.
2. Write answers in this Question/Answer Booklet.
3. You must be careful to confine your responses to the specific questions asked and to follow any instructions that are specific to a particular question.
4. Working or reasoning should be clearly shown when calculating or estimating answers.
5. Spare pages are included at the end of this booklet. They can be used for planning your responses and/or as additional space if required to continue an answer.
  - Planning: If you use the spare pages for planning, indicate this clearly at the top of the page.
  - Continuing an answer: If you need to use the space to continue an answer, indicate in the original answer space where the answer is continued, i.e. give the page number.  
Fill in the number of the question(s) that you are continuing to answer at the top of the page.

**SECTION A: Short Answers**

Marks Allotted: 54 marks out of total of 180 marks (30%)

Attempt **ALL** 14 questions in this section. The marks for each question are indicated in brackets. Answers are to be written in the space below or next to each question.

1. a) Explain the conditions under which **sound beats** are produced.

[2 marks]

- b) Whilst tuning up, a member of an orchestra noticed that she can hear a note pulsating at a rate of 6 beats per second. Below is a list of frequencies produced by various instruments in the orchestra.

Oboe: 476 Hz    Violin: ~~480~~ Hz    Cello: 244 Hz    Flute: 312 Hz    Saxophone: 250 Hz.

Which two instruments are producing the beats?

[1 mark]

2. A light-emitting diode (LED) can run at a safe voltage of 2.0 V and yet it can be connected effectively into a 12 volt circuit if a series resistor is used.

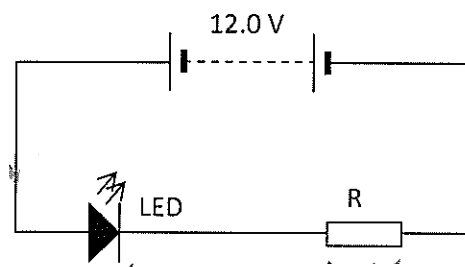

The circuit above shows an LED connected correctly into a 12 volt circuit. If the LED must not carry a current exceeding 10.0 mA, calculate the value of the resistor R to be used.

[3 marks]

3. Jacob rides his mountain bike, freewheeling down a track composed of gravel and sand. The bike remains stable when Jacob is going in a straight line but when he reaches a curved section of the track his wheels slide away and he crashes.

Explain why Jacob is more likely to crash when going into a curved section of the track.

4. A picture of mass 4.20 kg is hung from a nail in the wall by a wire, as shown in Figure 1.

If the wire makes an angle of  $35^\circ$  to the picture, calculate the tension in the wire.

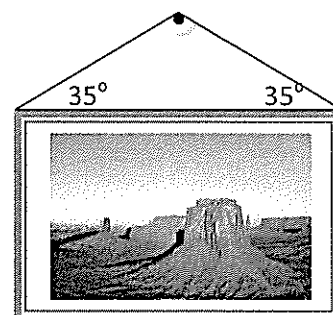

[4 marks]

5. A golf ball and a table-tennis ball with the same diameter are both dropped from the Leaning Tower of Pisa. The golf ball has a mass of 100 g and the table-tennis ball has a mass of 5.0 g.

Complete the table below to indicate which of the statements below are correct (draw a tick or a cross to indicate your choice).

		Tick / cross
A	Both balls will have the same downward force on them <del>at all times</del>	<input type="checkbox"/>
B	Both balls will have the same acceleration when they are dropped	<input type="checkbox"/>
C	Both balls will have the same acceleration half-way down	<input type="checkbox"/>
D	Both balls will hit the ground at the same time	<input type="checkbox"/>

[4 marks]

6. A company has produced three designs for coat hangers, shown below, each held to the wall with two bolts, X and Y.

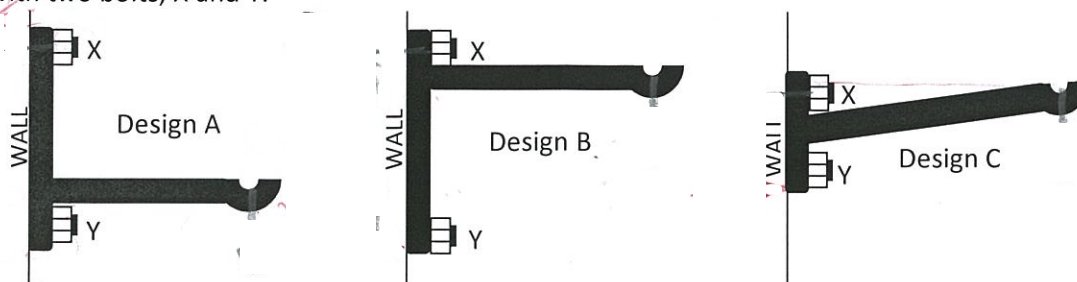

- a) Which bolt is most likely to be pulled out when a heavy coat is on the hanger? \_\_\_\_\_
- b) In which design is there the most force exerted on bolt X? \_\_\_\_\_
- c) Explain your answer to part b) above.

[4 marks]

7. A tennis ball thrown upwards at  $10.0 \text{ ms}^{-1}$  is calculated to reach a maximum height of 5.10 m with no air resistance, but is actually found to only reach a height of 4.80 m.
- a) Use these figures to calculate an average value for the acceleration of the ball as it travels upwards.

[3 marks]

- b) How does the time for the ball to come down compare with the time it takes to go up?

(Circle)      **LONGER**                      **SAME**                      **SHORTER**

[1 mark]

8. The Hubble constant can be expressed as  $2.5 \text{ kms}^{-1}$  per  $10^{17} \text{ km}$ .  
If a star is  $3 \times 10^{20} \text{ m}$  away from Earth, predict how fast this planet is moving away from earth.

[3 marks]

9. Galileo set up a “thought” experiment where a ship was moving to the right with a constant velocity and a sailor, who was sitting at the top of the mast, dropped a cannon ball. He asked the question as to where this cannon ball would land as it hit the deck.

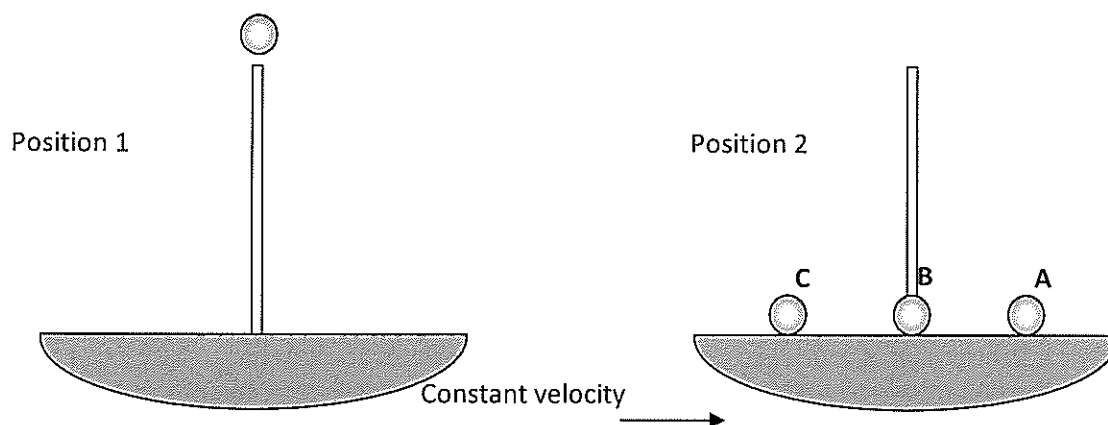

- a) Circle the point where you think the ball will land here: A B C [1 mark]
- b) Explain your choice of answer to part a).

[3 marks]

10. The neutrino was postulated in 1930 by Wolfgang Pauli to explain a feature of Beta decay

- a) Describe a neutrino.

[2 marks]

- b) Describe the process that occurs inside a nucleus to produce a neutrino

11. Scientists compared the spectrum of light absorbed by hydrogen in the laboratory with the spectrum of hydrogen absorbed by the atmosphere of a distant star. They noticed that the pattern of spacing between the lines was the same, but the wavelengths of the absorption lines were in a slightly different place, as shown below.

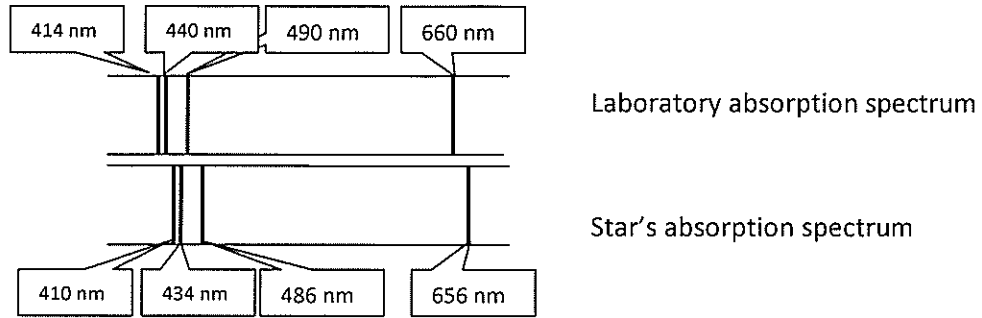

- a) Name this phenomenon observed with stars where the wavelength of spectral lines changes

[1 mark]

- b) Explain how this observed effect comes about

[3 marks]

- c) What data can be obtained from the change in wavelength of light emitted from stars.

[1 mark]

12.

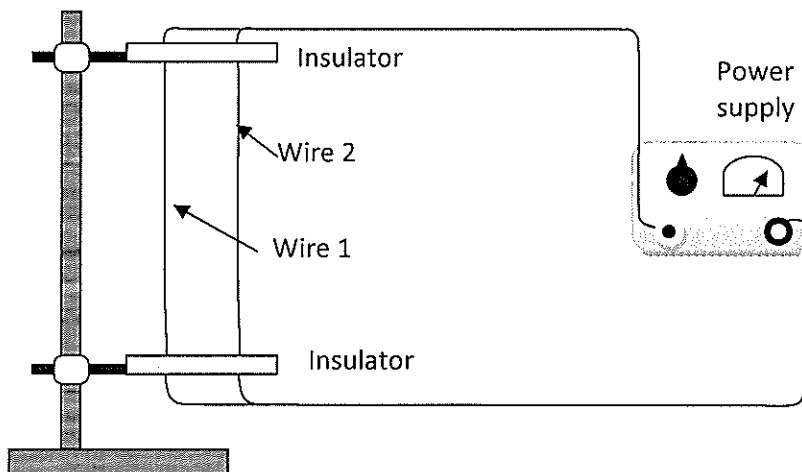

Two straight wires are suspended vertically from a stand, each held by a strip insulator, as shown in Diagram 2 above.

- a) Which of the statements below concerning the force between the wires is true? (Circle the correct answer.)
- A. There will be a magnetic force of attraction between the two wires
  - B. There will be a magnetic force of repulsion between the two wires
  - C. The force between the wires cannot be determined as we do not know the direction of the currents
  - D. There will be no magnetic force between the two wires

[1 mark]

The diagram below represents the current flow in the wires in a different experiment, as seen from above.



- b) Draw in the shape of the resultant magnetic field around the wires.

[3 marks]

13. Water waves move slower in shallower water than in deep water, which is the cause of surf breakers in W.A. Complete the diagram below to show the accurate shape and pattern of waves coming into shore at an angle as they move from the deep to the shallower water near the beach. Draw in 4 more waves on the diagram below as they move through the shallow water.

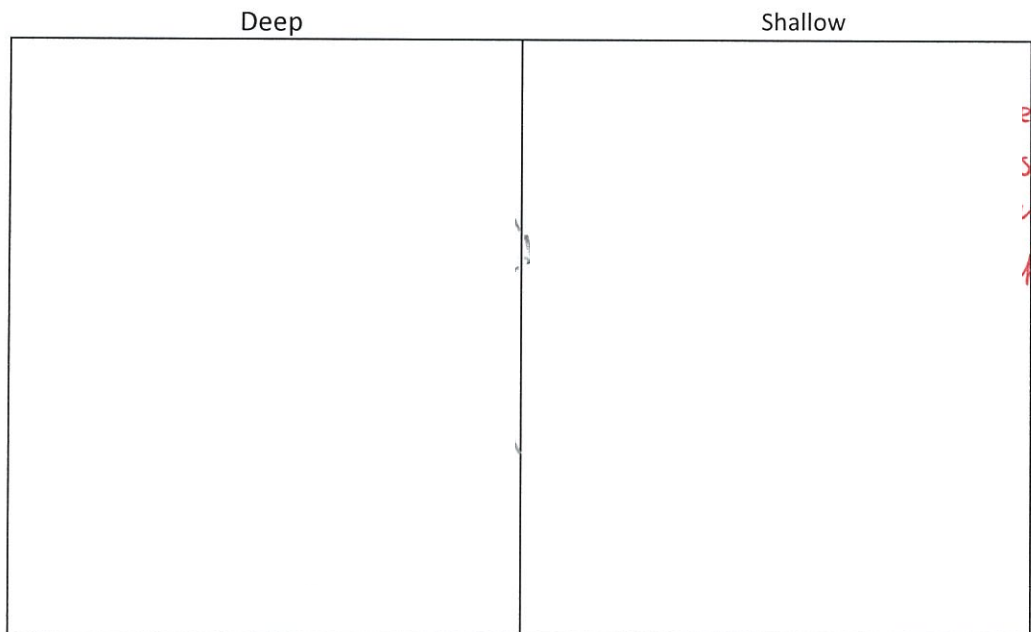

[4 marks]



14.

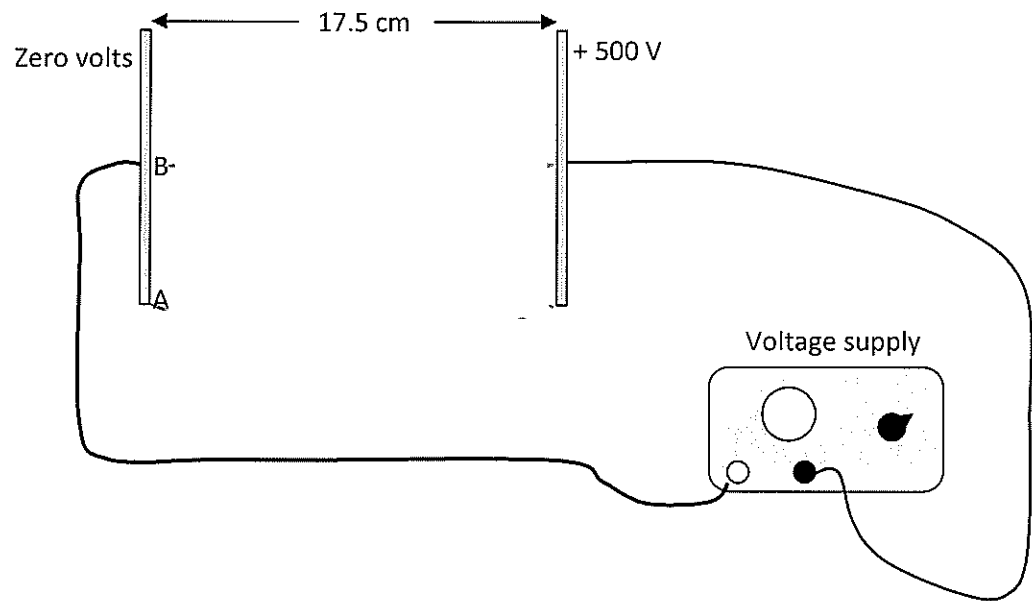

In an experiment two metal plates are attached to a 500 V power supply to produce an electric field  $E$  between the plates.

a) Calculate a value for  $E$  when the plates are placed 17.5 cm apart. [2 marks]

b) Two electrons are released at points A and B on the left hand plate which are attracted towards the right hand plate. Draw in on the diagram the paths of each of these electrons as they move from left to right.

[2 marks]

Section B Problem-Solving 90 marks out of 180 (51%)

1. (12 marks)

Plucky McGinty likes to jump over buses on her trial bike. In an exhibition one day she rides her motorcycle up a ramp, over a bus and lands safely on the ramp at the other side. The left hand ramp has an incline of  $42.0^\circ$  and when she takes off the centre of gravity of Plucky and her machine is 2.40 m above the ground. Her speed at this point is  $45.0 \text{ km hour}^{-1}$ .

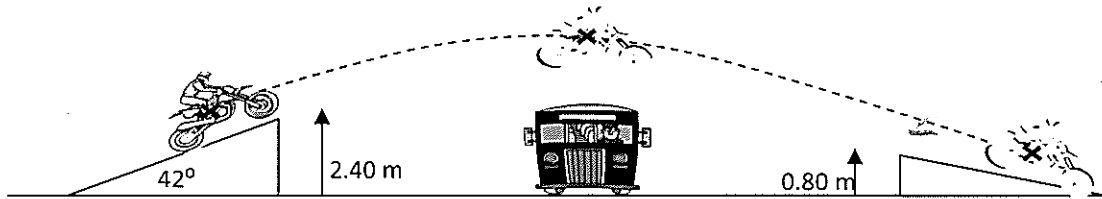

a) What is her vertical velocity when she takes off?

[2 marks]

b) What is the maximum height reached by Plucky and her bike (centre of gravity) above the ground?

[3 marks]

Plucky and her machine land on another ramp at the other side of the bus, at which point the centre of mass of the combination is 0.800 m above the ground.

c) What is the vertical speed of the motorcycle when Plucky lands?

[3 marks]

d) Calculate how far away, horizontally, the motorcycle is from its take-off position when it lands

[4 marks]

2. (16 marks)

Gemma decides to go fishing one day with her new rod and tripod. She sits on the banks of the Swan river and sets up the 900 gram rod, with the tripod, close to the bank with a cable at the left hand end anchored into the ground with a tent peg. The centre of mass of the rod is 1.00 m from the left hand end of the rod. She has not caught a fish yet!

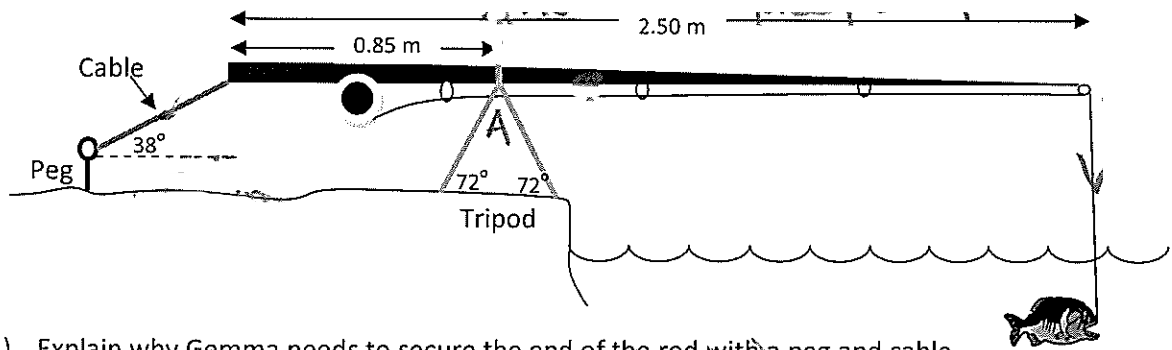

a) Explain why Gemma needs to secure the end of the rod with a peg and cable.

[2 marks]

b) Gemma eventually manages to hook a 1.50 kg fish on the end of her line. Draw in and name all the forces acting on the rod when the fish is caught, using arrows to show their directions.

[4 marks]

c) Calculate the **downwards** force that the cable has to exert to keep the rod in a horizontal position once the fish leaves the water.

[4 marks]

d) If the cable makes an angle of 38.0° to the ground, calculate the total force of tension needed in the cable when the fish is caught.

[2 marks]

e) If the legs of the tripod make an angle of 72° to the ground, calculate the compressive force in each leg of the tripod when the fish is on the end of the line.

[4 marks]

3. (12 marks)

A portable AC generator is hired by an Outback cricket team to power the spotlights needed for a night game. The cable linking the generator to the lights has a length of 700 m and a total resistance of  $7.50 \Omega$ . The lights consume an electrical power of  $2.40 \text{ kW}$  at a frequency of  $50.0 \text{ Hz}$  and an AC voltage of  $240 \text{ V}$  when they are operating at full power.

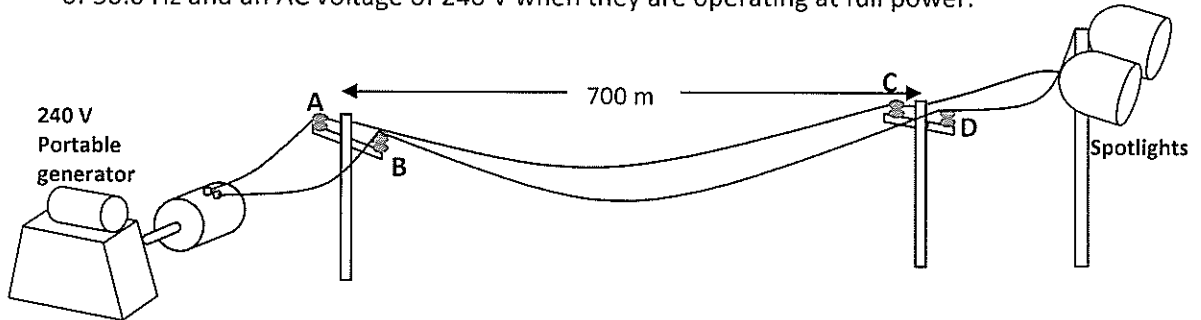

When testing the system, a voltmeter is connected across points A and B, and the generator is started up.

a) Which of the graphs below would display the voltage across points A and B as the generator is starting up and reaching full speed? (circle the correct answer).

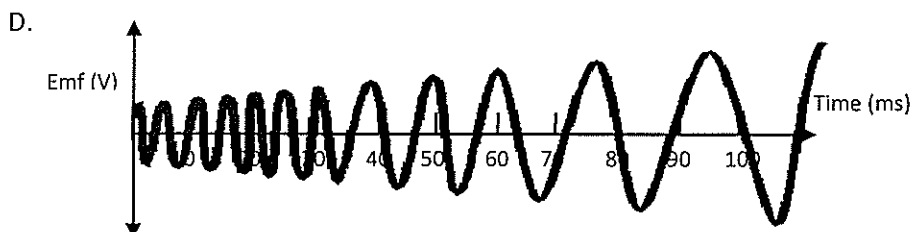
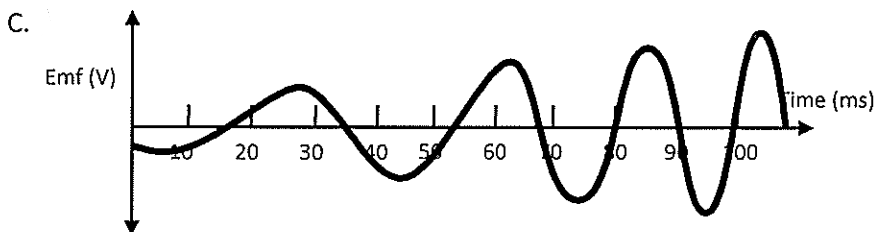
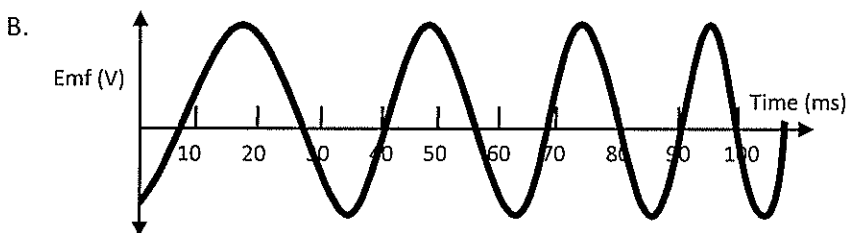
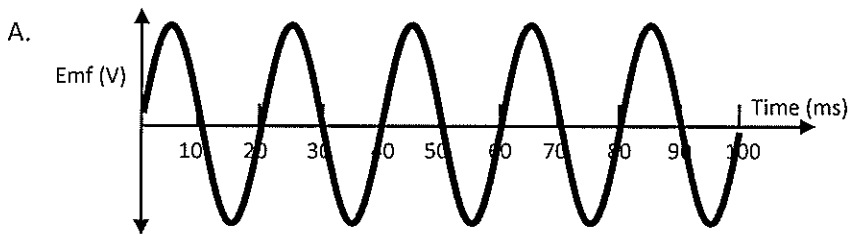

b) Explain your answer to part a)

[2 marks]

c) When the technicians test the voltage in the powerlines across points C and D they find that the voltage is no longer 240 V. Calculate the voltage delivered to the spotlights at CD.

[4 marks]

d) What is the power loss in the wires?

[2 marks]

When the lights are turned on they appear much dimmer than they should be and the technicians realise that there is a design fault in the system. They remedy this by installing transformers at points AB and CD in the cables.

e) Explain how this modification produces brighter lights at the cricket ground.

[3 marks]

4. (11 marks)

Emma has just made a model doll's house for her brother and has designed a lighting system for the 3 rooms with facility for dimming the lights and for turning each one on separately.

- a) Explain why Emma must use a parallel circuit for the lighting system, instead of a series circuit.

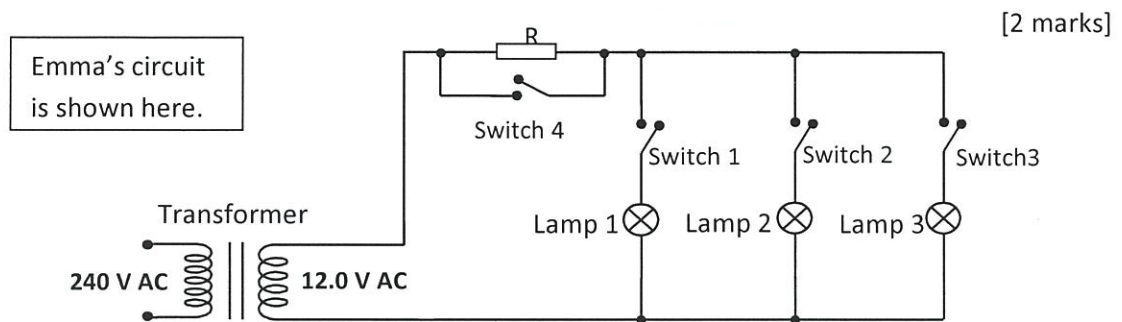

- b) Explain how switch 4 and the resistor are able to produce a dimming effect on the three lamps.

[3 marks]

- c) Each of the lamps is manufactured to run on 12.0 volts and uses a power of 4.80 W. Calculate the current supplied by the Secondary coil of the transformer when all 3 lamps are on and **not dimmed**.

[2 marks]

- d) Assuming that the transformer is 90% efficient, calculate the input current required to the primary coil of the transformer when all three lamps are connected into the circuit at full brightness.

[3 marks]

- e) The value of R has been chosen so that when it is connected into the circuit with all three lamps also connected only **half** the normal current runs through them. Calculate a value for the resistor R.

[2 marks]

5. (13 marks)

A 200 kg GPS satellite orbits the Earth at a height of 19,300 km above its surface.

a) Calculate the Earth's gravitational force on the satellite in its orbit.

[3 marks]

b) Show that this satellite orbits the Earth at a rate of about twice per day.

[3 marks]

c) Explain why the height of GPS satellites remains the same and yet they are said to be 'Falling towards the Earth'.

[2 marks]

d) A digital signal is sent from the satellite to the GPS receiver in a car on Earth and is received back again after a time delay of 233 ms. What is the distance of the car from the satellite?

[2 marks]

The planet Syzygy has been discovered in another galaxy which could possibly have conditions to support life as we know it if its gravitational field strength is large enough to attract and hold molecules of oxygen, which is estimated to be  $> 5.6 \text{ N kg}^{-1}$ .

e) If the radius of the planet is 0.85 times Earth's radius and its mass is 0.34 times Earth's mass, calculate a value for 'g' on the surface of Syzygy and state whether it is likely to be able to support life.

[3 marks]

6. (13 marks)

A domestic microwave oven is rated at 500 W and uses a frequency of 2500 MHz.

- a) How many microwave photons would be produced in the 50.0 seconds it takes to heat a mug of coffee in the oven?

[3 marks]

- b) The microwaves emitted inside a microwave oven can form standing waves as they are reflected off the metal walls. The distance between the left and right hand walls of the microwave is 48.0 cm and the distance from the top to the bottom is 30.0 cm.

Calculate the wavelength of the microwaves and use the results to draw shapes on the diagram below to illustrate the standing wave existing across the width of the oven.

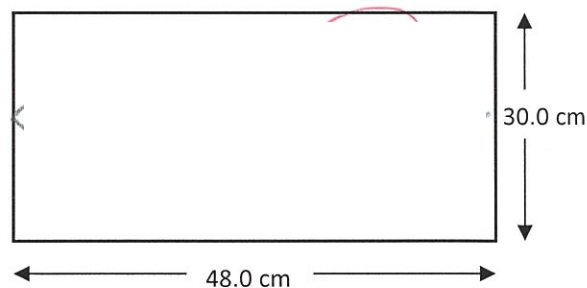

[3 marks]

When a solution of calcium chloride is sprayed into a Bunsen burner flame, a red colour is produced (due to the calcium atoms). With a solution of copper chloride a green colour is produced (due to the copper atoms).

- c) Explain why calcium and copper produce different coloured flames.

[2 marks]



The diagram shows the energy levels for an element X.  $E_1$  is the lowest energy state that an electron can have.

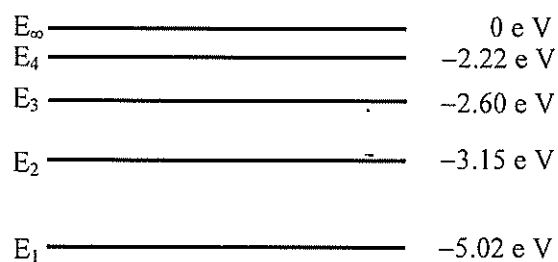

d) Explain why gaseous elements in a flame only give out a series of coloured lines in their spectrum and not a complete spread of colours of the rainbow.

[2 marks]

e) Calculate the wavelength of the spectral line produced when a transition occurs between energy levels  $E_3$  and  $E_2$ .

[3 marks]

- c) It was suggested by a researcher that one of the results had an error in it. Circle the result that you think is in error and draw a line of best fit through the rest of the points.

[2 marks]

- d) Calculate a value for the gradient of the graph and use this to estimate a value for the magnetic flux density in the chamber.

[4 marks]

- e) Many sub-atomic particles have been discovered by accelerating electrons and colliding them with stationary atoms. However, in the latest model of matter, it is proposed that these sub-atomic particles are, themselves, composed of even smaller particles called *Quarks*, with electronic charges that are only a fraction of that on an electron.

Using the proton and a neutron as examples, show how a combination of three quarks can make up baryons such as these.

[2 marks]

- f) A velocity filter, consisting of an electric field and a magnetic field at right angles to one another, is used to ensure that the charges reaching the mass spectrometer have the same velocity. Sketch an arrangement of electric and magnetic fields that could be used.

[2 marks]

7. (13 marks)

In an experimental Australian physics laboratory a mass spectrometer is being used to identify different elements from a forensic experiment. The specimens are first vaporised and ionised, these ions are then accelerated to a common velocity of  $2.00 \times 10^5 \text{ m s}^{-1}$ . These singly-charged ions are injected into the magnetic field in the chamber so that the ion beam falls a certain distance away on the detector.

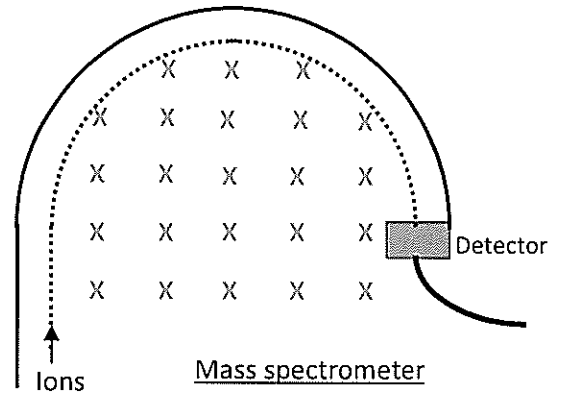

a) If the magnetic field in the chamber extends downwards into the page, state the sign on the particles reaching the detector (circle the answer below).

Negative       Neutral       Positive

[1 mark]

b) Derive the expression  $r = \frac{mv}{Bq}$  linking the radius of the ionic path with the mass of the ion and use it to explain why ions with a particular mass-to-charge ratio must move in a circle with one value of radius.

[2 marks]

A graph is shown below of the radius of the curve against the mass of each ion. The masses are plotted in atomic mass units (amu).  $1 \text{ amu} = 1.67 \times 10^{-27} \text{ kg}$ .

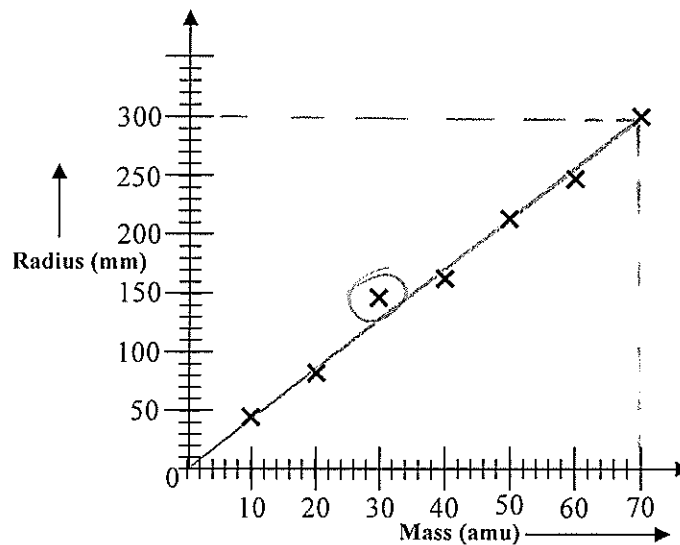

## Question 1 (18 marks)

## The Australian Synchrotron

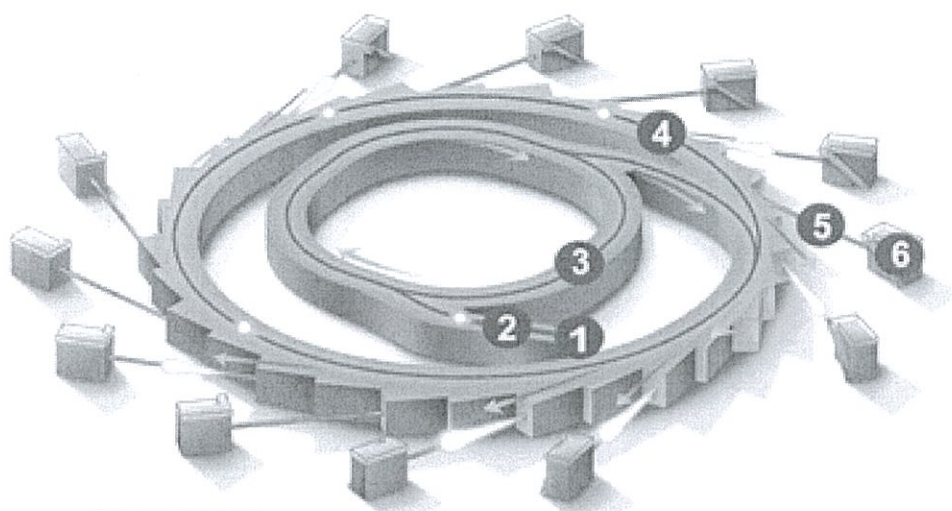

1. electron gun
2. linac
3. booster ring
4. storage ring
5. beamline
6. end station

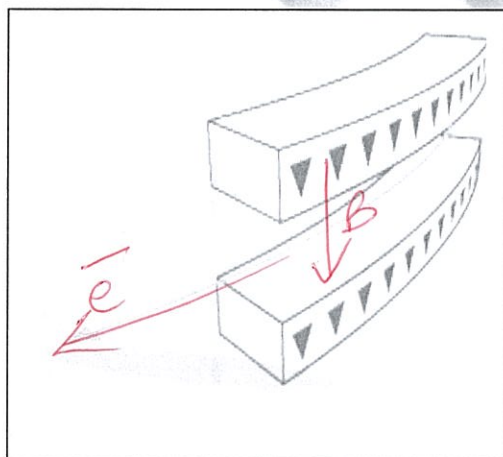

*Illustration of a bending magnet.  
At each deflection of the electron path a beam of light is produced.  
The effect is similar to the sweeping of a search light.*

Figure (ii)

Synchrotron light is the electromagnetic radiation emitted when electrons, moving at velocities close to the speed of light, are forced to change direction under the action of a magnetic field. The electromagnetic radiation is emitted in a narrow cone in the forward direction, at a tangent to the electron's orbit.

Synchrotron light is unique in its intensity and brilliance and it can be generated across the range of the electromagnetic spectrum: from infrared to x-rays.

#### How is synchrotron light created?

Beamline specifications:

Source: 1.9 Tesla wiggler magnet

Available energy range 4 - >50 keV in 16 m diameter storage ring

Beam size at sample (horizontal x vertical) is 0.5 mm (h) x 0.2 mm (v)

Photon flux at sample >  $5 \times 10^{12}$  photons / second

- c) Why is synchrotron radiation preferable to normal x-ray therapy in the treatment of cancers?

It is more intense so lower doses can be given

[2 marks]

- d) One of the features of synchrotron radiation is that the location of specific elements can be accurately located within the body.

Give an example where this ability could be valuable for use in Forensic Science.

[2 marks]

- e) By equating the 50 keV electrical energy given by the Linac with the kinetic energy, calculate a value for the velocity of the electrons emerging from it and hence the centripetal force acting on them.

[5 marks]

- f) The final energy of photons colliding with the target sample is around  $4 \times 10^{-14}$  J. What would the wavelength of the emerging electromagnetic waves be?

[3 marks]

- g) From the beam size data given, calculate a value for the power absorbed per square metre when  $5 \times 10^{12}$  photons strike the target per second.

[3 marks]

Question 2 (18 marks)

**Vehicles moving through fluids**

You may have wondered why all vehicles such as cars and boats reach a maximum speed and cannot go any faster, even though they have a constant driving force on them. The answer is that, as a vehicle goes faster, the force opposing the motion (called Drag) increases, according to the formula:

Equation 1

$$F_D = \frac{1}{2} \rho v^2 C_d A$$

where:  $F_D$  is the drag force  
 $\rho$  is the density of the fluid  
 $v$  is the velocity of the vehicle  
 $A$  is the frontal area of the vehicle.  
 $C_d$  is called the Drag Coefficient of the object and is a constant which depends on how streamlined the object is. For a car,  $C_d$  ranges from about 0.25 to about 0.45.

- a) Calculate a value for the Drag Force on a car with a frontal area of  $2.45 \text{ m}^2$  and a Drag Coefficient of 0.35 moving at a speed of  $72 \text{ kmhour}^{-1}$  (take the density of air as  $1.20 \text{ kgm}^{-3}$ ).

[3 marks]

- b) When the car referred to in part a) is moving at its maximum velocity of  $198 \text{ kmhour}^{-1}$  (terminal velocity), what force is being exerted by the engine moving the car forwards?

[3 marks]

The Terminal velocity of any object moving in a fluid is given by

Equation 2

$$v_T = \sqrt{\frac{2W}{\rho A C_d}}$$

where:  $v_T$  is the Terminal Velocity of the object  
 $W$  is the weight of the object  
 $\rho$  is the density of the fluid  
 $A$  is the frontal area of the object  
 $C_d$  is the Drag Coefficient of the object

An experiment was set up at the Naval Base laboratory to investigate the terminal velocity of a spherical ball shaped object moving through water. It was hoped that this might help in the design of more efficient submarine hulls. A diagram of the experiment is shown below.

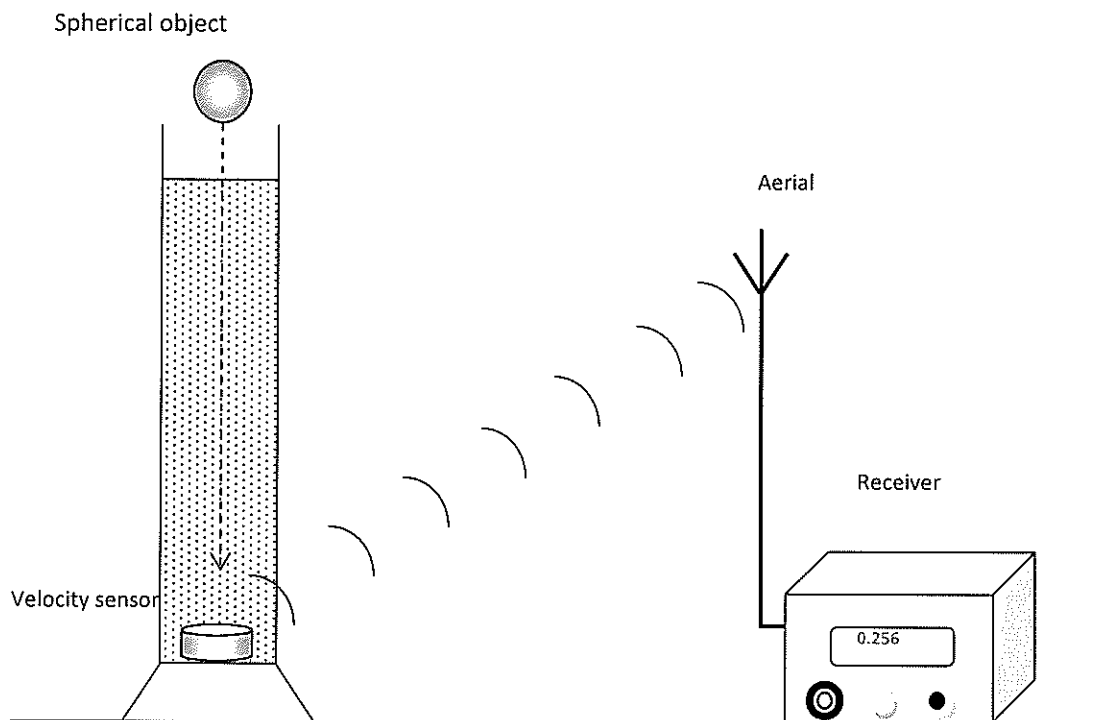

The sphere was allowed to fall in a column of water with a radar velocity sensor positioned at the bottom. The velocity of the ball was transmitted via radio waves to a receiver which gave a digital read-out of the sphere's velocity. Various balls of the same diameter but different masses were used and readings of  $V_T$  recorded for each different sphere. The results are shown in Table 2.

Velocity $v_T$ ( $\text{ms}^{-1}$ )	Mass (g)	Weight (N)	$v_T^2$ ( $\text{m}^2\text{s}^{-2}$ )
0.37	10		
0.55	22		
0.69	42		
0.83	50		
1.02	75		

Table 2

- c) Fill in the last two columns of Table 2, inserting values for the weight of the sphere and the square of the sphere's terminal velocity.

[2 marks]

- d) Explain why a plot of  $v_T^2$  against  $W$  would give a straight line graph.

[2 marks]

- e) Plot the points of the graph of  $v_T^2$  (up) against  $W$  (along) on the graph paper on the next page and draw an appropriate line of best fit.

[4 marks]

- a) Calculate the gradient of your line of best fit. Show points on the graph used in your calculation.

[2 marks]

- b) From Equation 2 above, calculate a value for  $C_d$  for the sphere, given that:

$$\rho = 1.10 \times 10^3 \text{ kg m}^{-3}$$

$$A = 2.8 \times 10^{-3} \text{ m}^2$$

[2 marks]



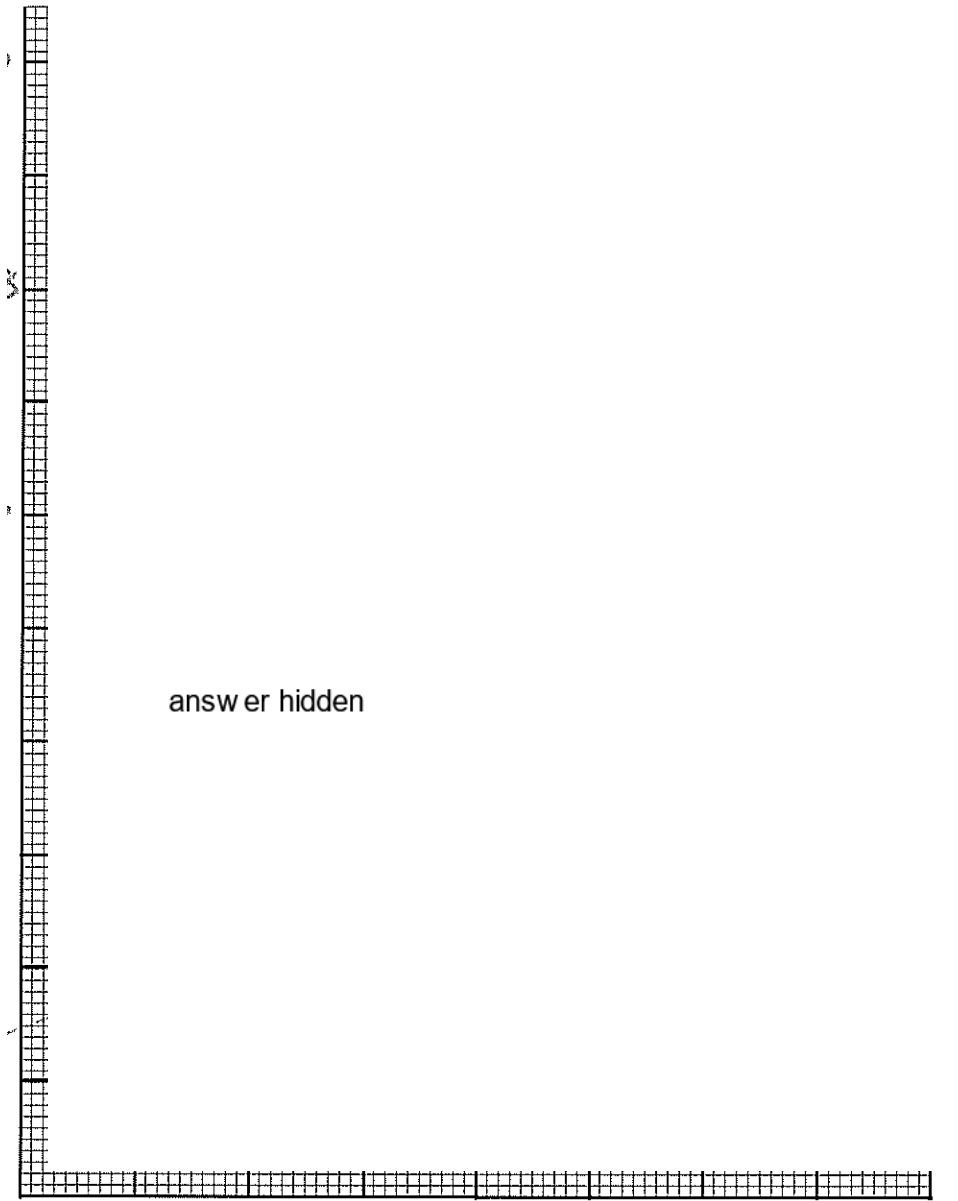

Reference for Section C, Question 1 [www.synchrotron.org.au](http://www.synchrotron.org.au)

End of Paper

